

NOTES:

1. ASPHALT CONCRETE MIX SHALL BE HMA CLASS ½" OR CLASS 1" PG 64-22.
2. ALL TRENCH BACKFILL SHALL BE CSTC OR CONTROLLED DENSITY FILL.
3. CONTROLLED DENSITY FILL SHALL MEET WSDOT STANDARDS AS STATED IN 2-09.3(1)E OF THE STANDARD SPECIFICATIONS FOR ROAD, BRIDGE AND MUNICIPAL CONSTRUCTION MANUAL M41-10, CURRENT EDITION.
4. ALL SAW CUTS SHALL BE VERTICAL AND IN STRAIGHT LINES AS DIRECTED BY ENGINEER.
5. TACK ASPHALT FACES OF SAW CUTS AND SEAL SAW CUTS WITH PG 64-22 OIL.
6. HOT MIX ASPHALT SHALL BE A MINIMUM OF 6 INCHES THICK ON LOCAL STREETS.
7. PAVING FABRIC (IF FOUND) WILL NOT REQUIRE REPLACEMENT.

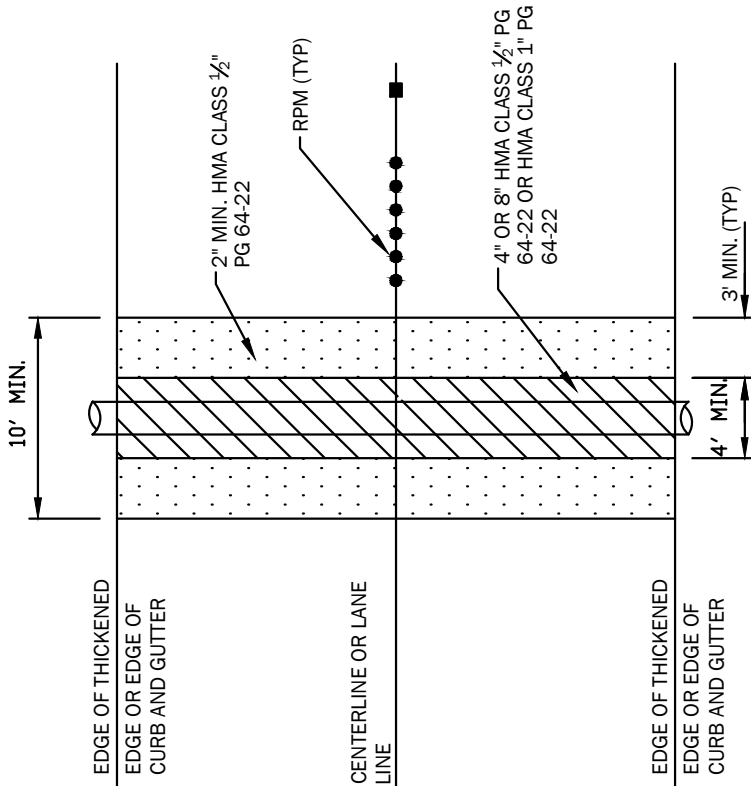

2" DEPTH OF GRIND OR SAWCUT

PLAN

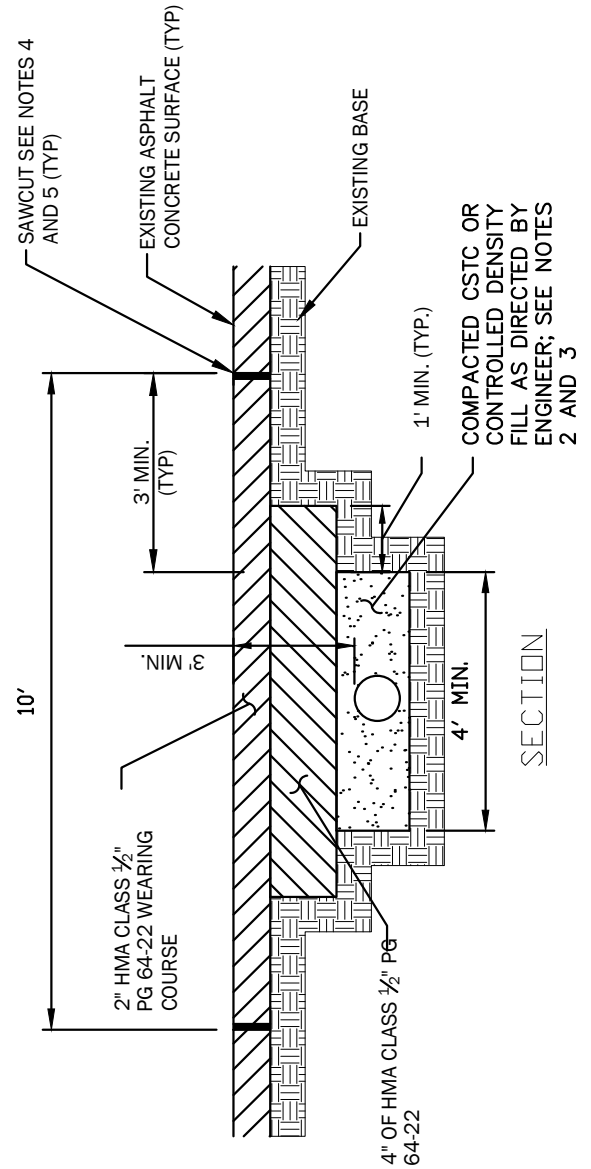

SECTION

TOWN OF YARROW POINT

4030 95TH AVENUE NE
 YARROW POINT, WA 98004
 P: (425) 454-6994 F: (425) 454-7899
 townhall@ci.yarrow-point.wa.us
 www.ci.yarrow-point.wa.us



ASPHALT PAVEMENT PATCHING AND RESTORATION DETAILS

RD-13a

LAST REVISED: 04/06/17